

REMOTE CONTROLLER WITH FIVE FUNCTIONS

Features

- Wide operating voltage range: 2.4V to 5.0V
- Low Standby current
- Auto Power-OFF function for TX2
- Few external components needed

General Description

The TX2/RX2 are a pair of CMOS LSIs designed for remote controlled car applications. TX2 is built with auto Power-OFF function. The TX2/RX2 has five control keys controlling the motions (i.e. Forward, Backward, Rightward, Leftward and Turbo function) of the remote controlled car.

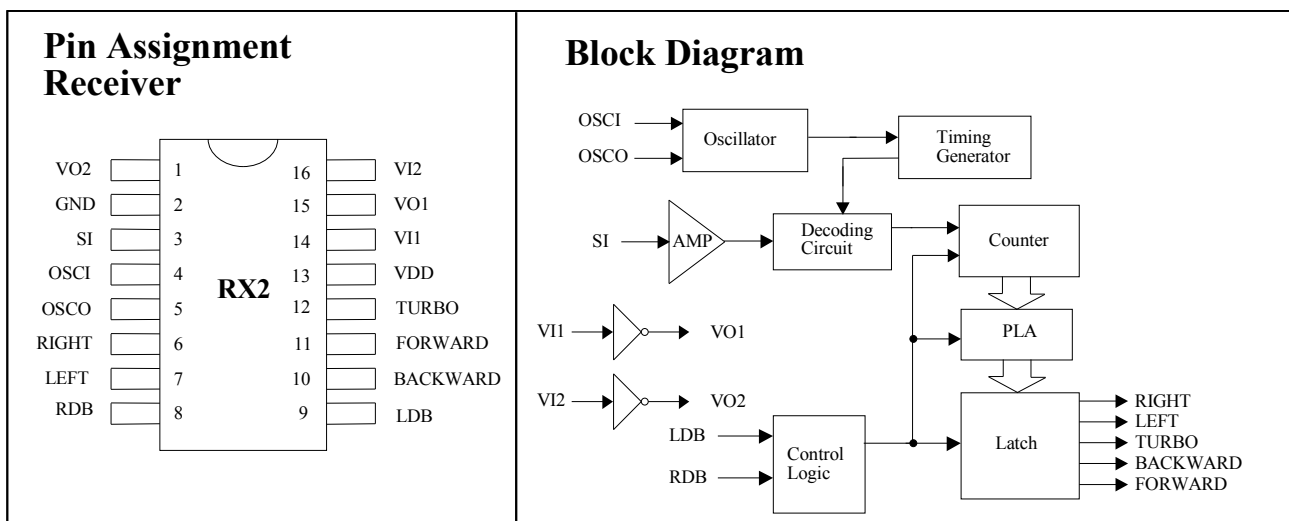
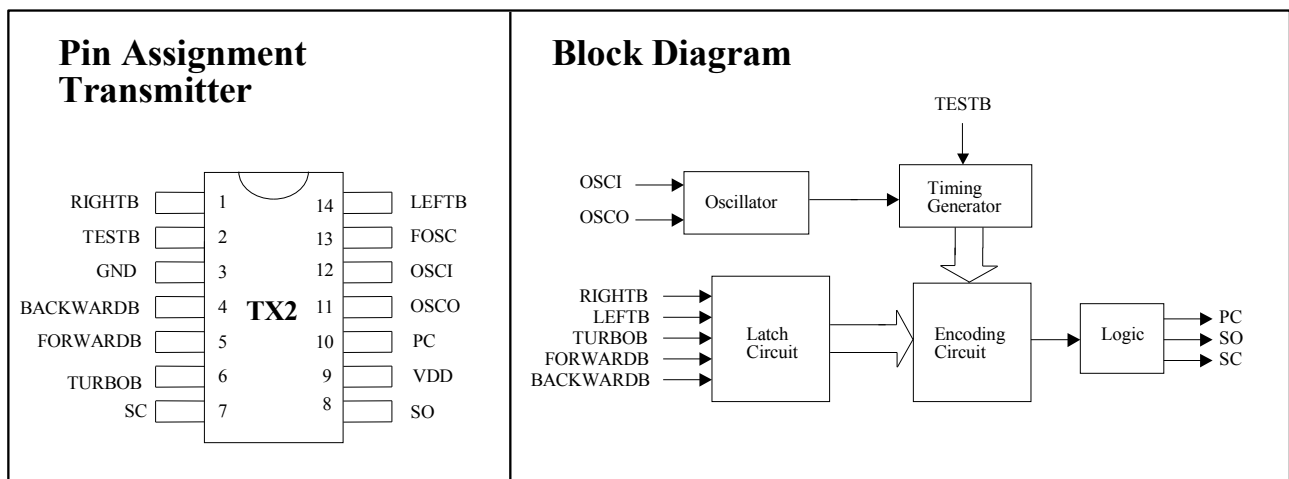

Absolute Maximum Ratings

Comments*

DC Supply Voltage.....0.3V to 5.0V
 Input/Output Voltage.....GND -0.2V to VDD + 0.2V
 Operating temperature.....-10°C to 60°C
 Storage Temperature.....-25°C to 125°C

Never allow a stress to exceed the values listed under "Absolute Maximum Ratings", otherwise the device would suffer from a permanent damage. Nor is a stress at the listed value be allowed to persist over a period, since an extended exposure to the absolute maximum rating condition may also affect the reliability of the device, if not causing a damage thereof.

Electrical Characteristics

TX2

(VDD=4.5V, Fosc = 128KHz, TA=25°C, unless otherwise specified.)

Parameter	Symbol	Min.	Typ.	Max.
Operating Voltage	VDD	2.4V	4.0V	5.0V
Operating Current	I _{dd}	-	-	1mA
Stand-by Current	I _{stb}	-	-	1μA
DC O/P Driving Current	I _{drive}	5mA	-	-
AC O/P Driving Current	I _{drive}	5mA	-	-
AC O/P Frequency	F _{audio}	500Hz	-	1KHz

RX2

(VDD=4.0V, Fosc = 128KHz, TA=25°C, unless otherwise specified.)

Parameter	Symbol	Min.	Typ.	Max.
Operating Voltage	VDD	2.4V	4.0V	5.0V
Operating Current	I _{dd}	-	-	1mA
O/P Driving Current	I _{drive}	1mA	-	-
O/P Sinking Current	I _{sink}	1mA	-	-
Effect Decoding Frequency Variation	F _{tolerance}	-20%	-	20%

Pin Description

TX2

Pin No.	Designation	Description
1	RIGHTB	The rightward function will be selected when this pin is connected to GND.
2	TESTB	This pin is used for testing purpose only.
3	GND	Negative power supply
4	BACKWARDB	The backward function will be selected when this pin is connected to GND.
5	FORWARDB	The forward function will be selected when this pin is connected to GND.
6	TURBOB	The turbo function will be selected when this pin is connected to GND.
7	SC	Output pin of the encoding signal with carrier frequency
8	SO	Output pin of the encoding signal without carrier frequency
9	VDD	Positive power supply
10	PC	Power control output pin
11	OSCO	Oscillator output pin
12	OSCI	Oscillator input pin
13	FOSC	This pin is used for testing mode.
14	LEFTB	The leftward function will be selected when this pin is connected to GND.

RX2

Pin No.	Designation	Description
1	VO2	Inverter 2 output pin for power amplify
2	GND	Negative power supply
3	SI	Input pin of the encoding signal
4	OSCI	Oscillator input pin
5	OSCO	Oscillator output pin
6	RIGHT	Rightward output pin
7	LEFT	Leftward output pin
8	RDB	Rightward function is disabled when this pin is connected to GND.
9	LDB	Leftward function is disabled when this pin is connected to GND.
10	BACKWARD	Backward output pin
11	FORWARD	Forward output pin
12	TURBO	TURBO output pin
13	VDD	Positive power supply
14	VI1	Inverter 1 input pin for power amplify
15	VO1	Inverter 1 output pin for power amplify
16	VI2	Inverter 2 input pin for power amplify

Code Format

Encode Rule

(A) Bit Format

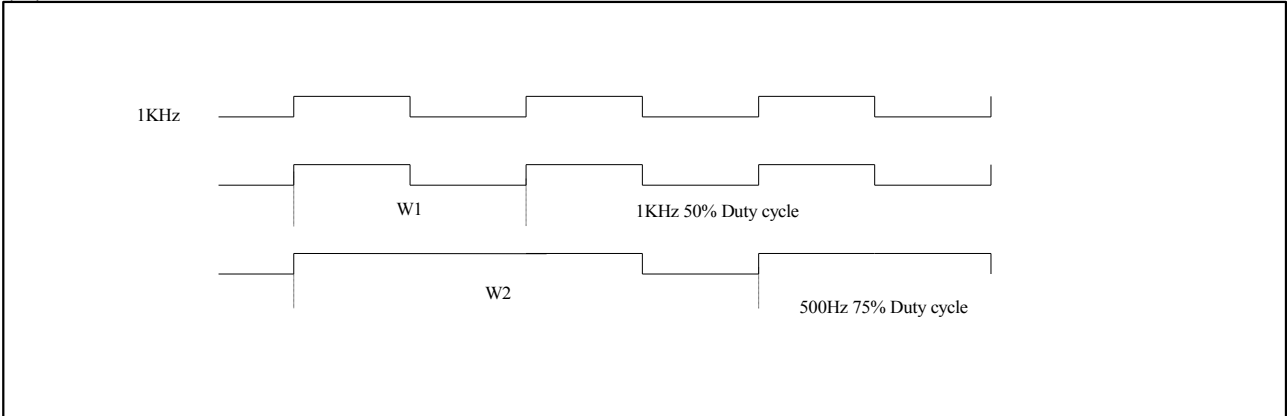

Data Format

W2 W2 W2 W2 (n) x W1 W2 W2 W2 W2 (n) x W1 W2 W2 W2 W2

Number of Function Codes (n) W1	Function Key	Decode Result
4		End Code
10	Forward	Forward
16	Forward & Turbo	Forward
22	Turbo	Turbo
28	Turbo & Forward & Left	Forward & Left
34	Turbo & Forward & Right	Forward & Right
40	Backward	Backward
46	Backward & Right	Backward & Right
52	Backward & Left	Backward & Left
58	Left	Left
64	Right	Right

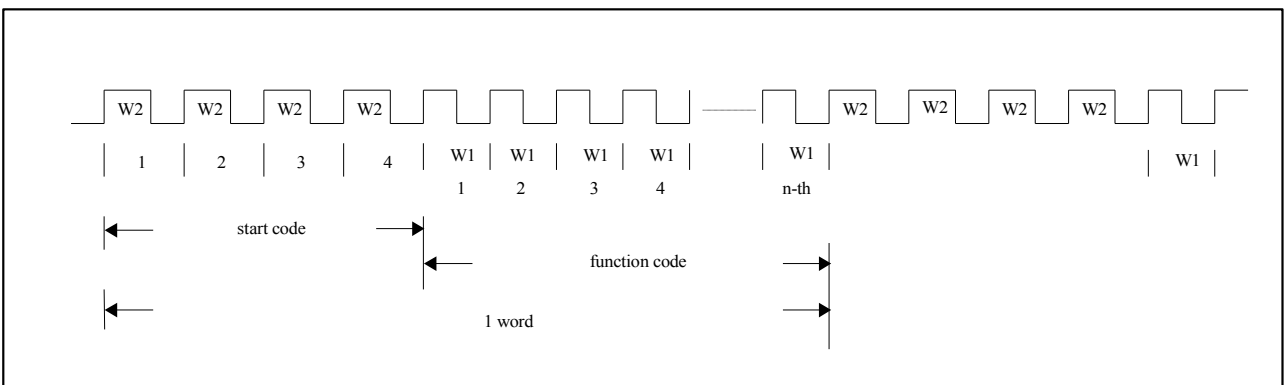

Encode/Decode Timing

(A)

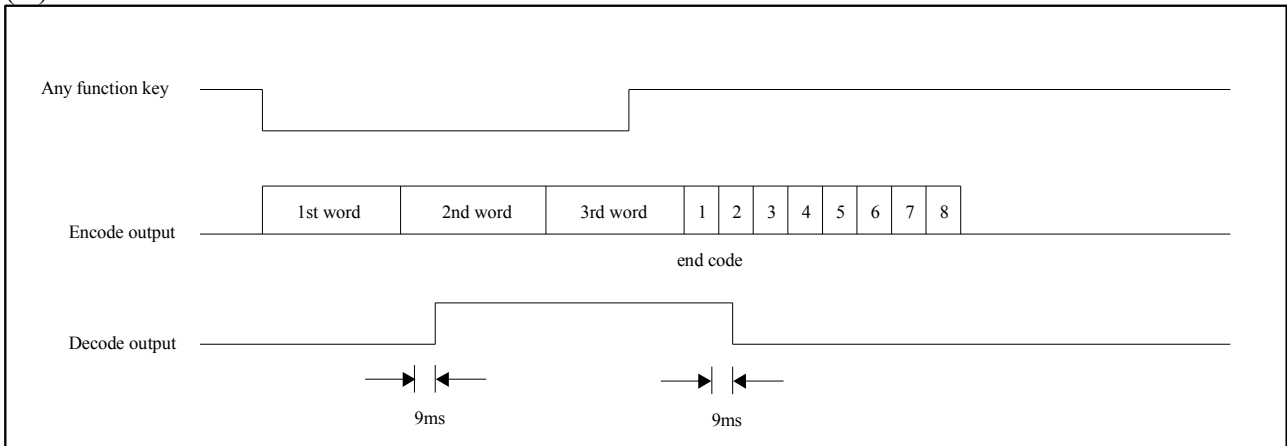

(B)

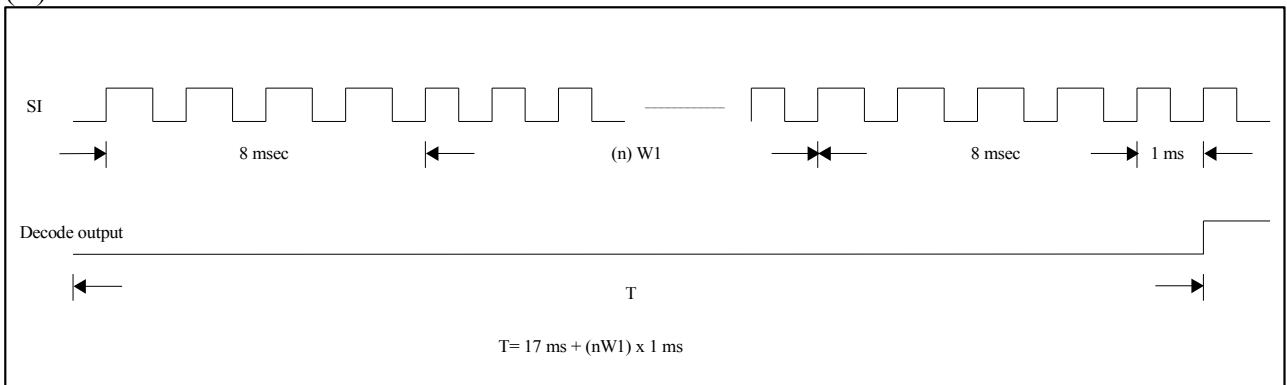

Typical Application Circuit

Transmitter (TX2 Fosc \cong 128 KHz)

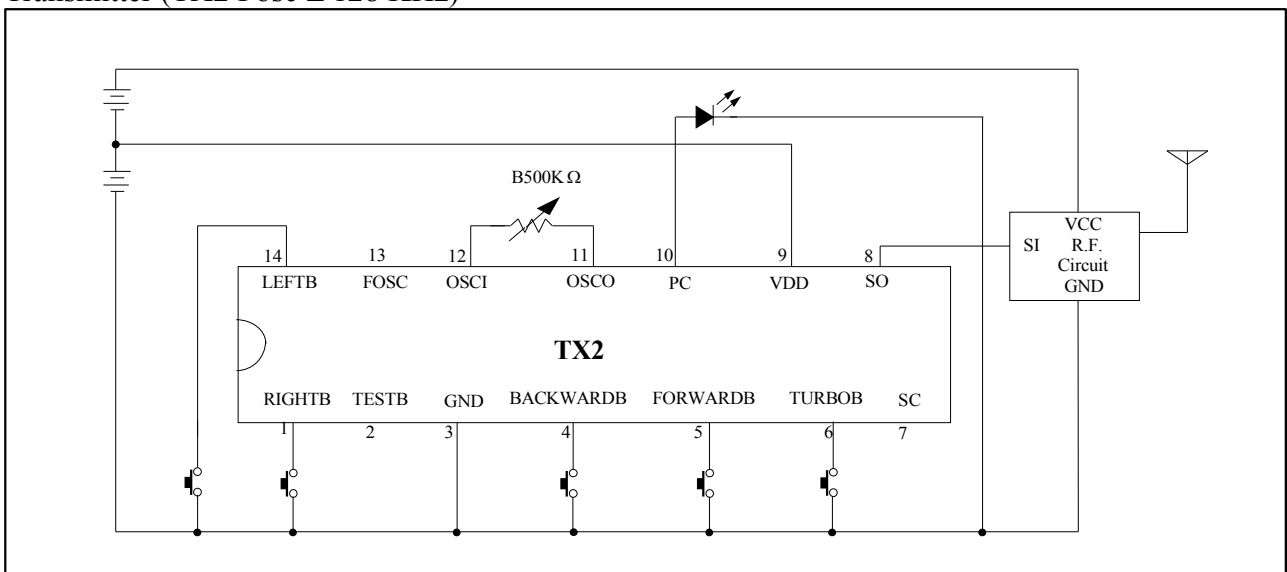

Receiver (RX2 Fosc \cong 128 KHz)

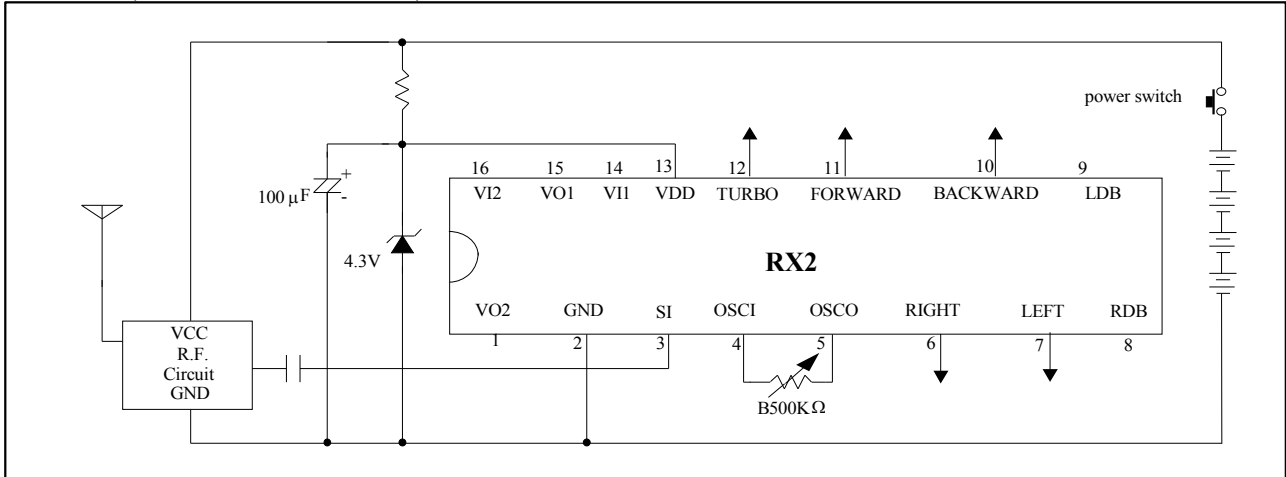

Infrared Application Circuit

Transmitter

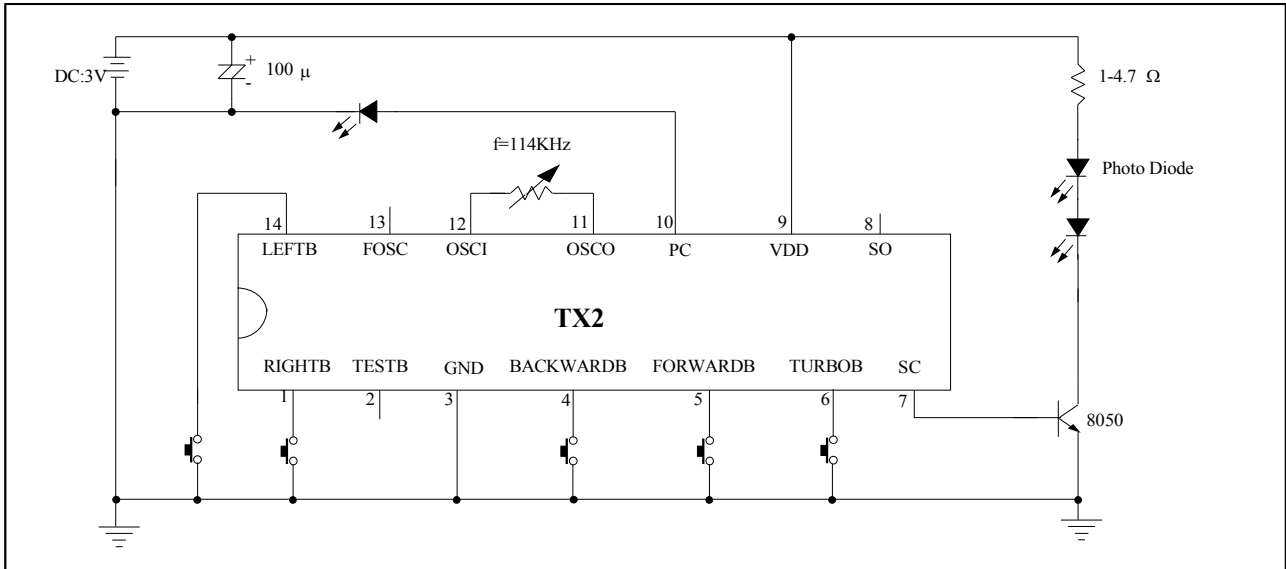

Receiver

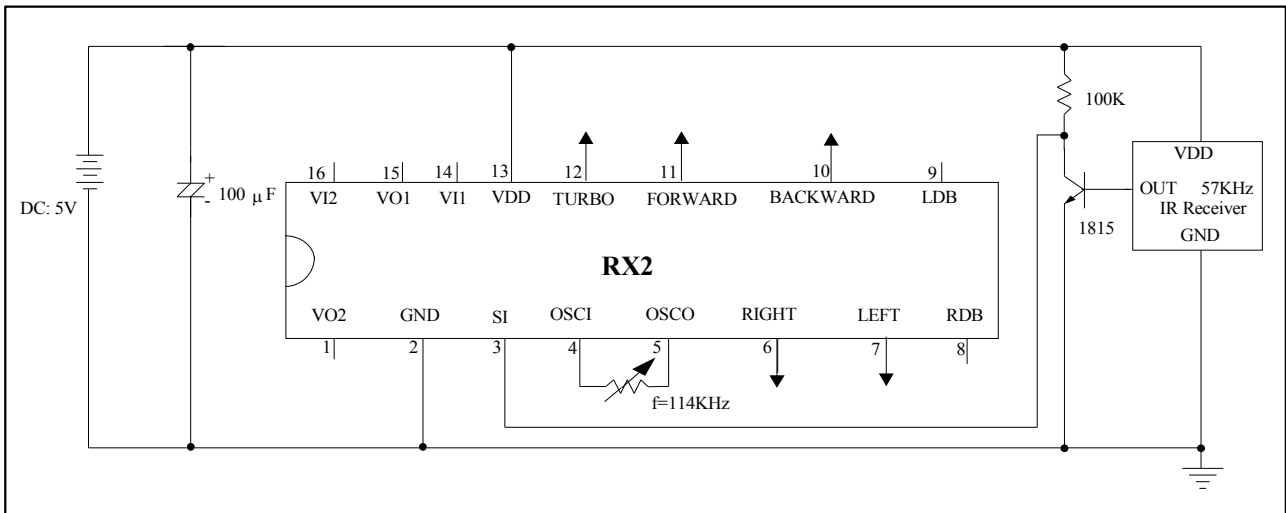

Testing Circuit

Fosc for TX2 \cong Fosc, RX2 \cong 128 KHz

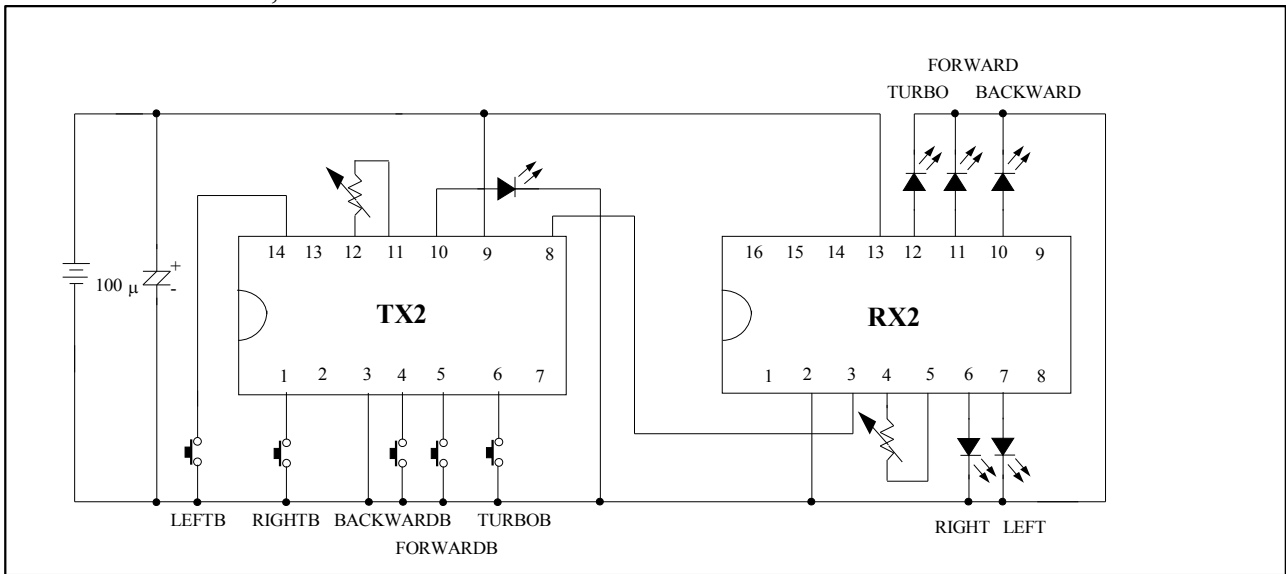

Bonding Diagram

TX2

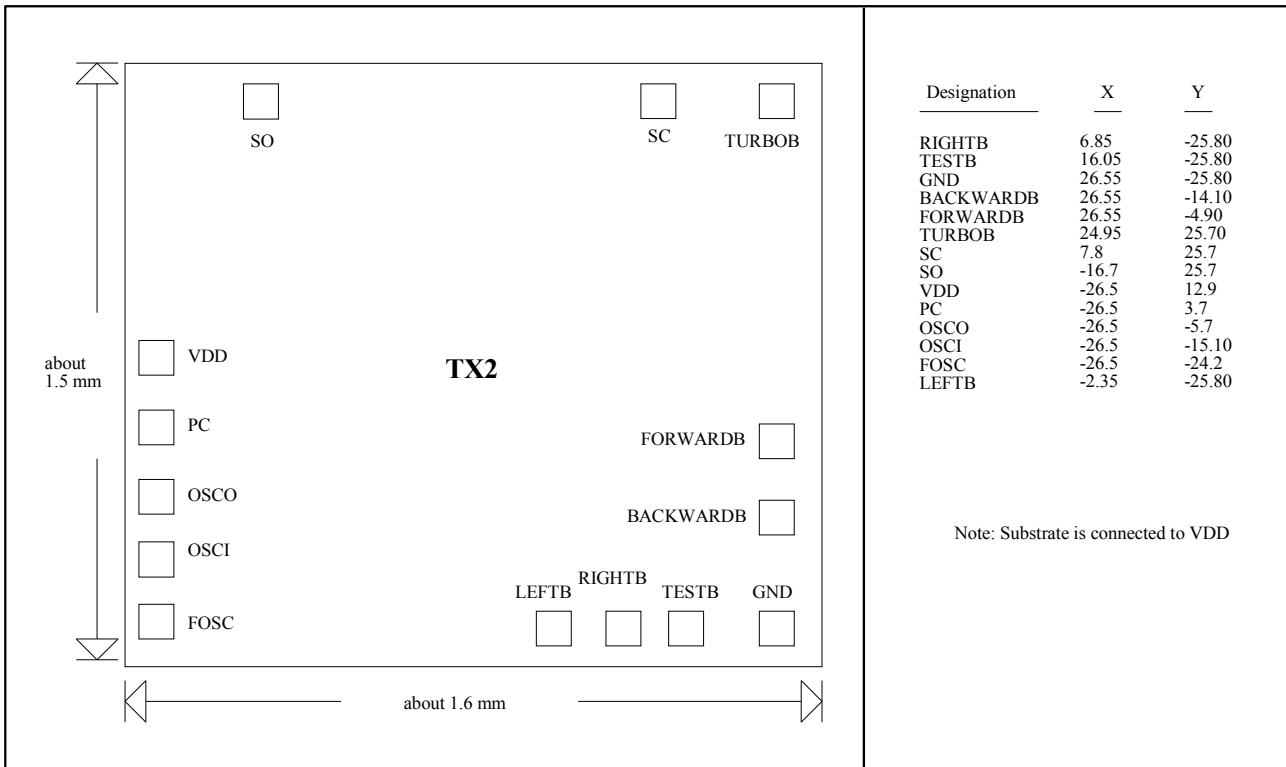

RX2

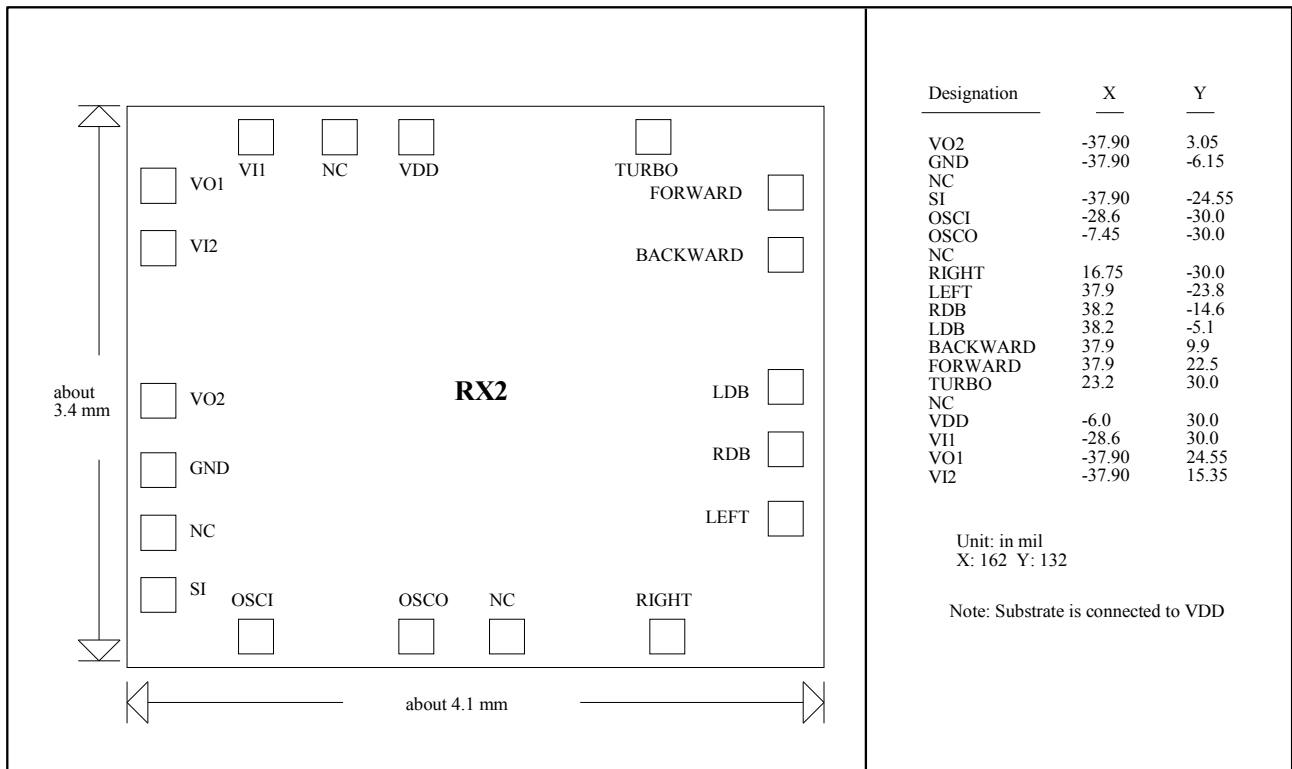

Notice: REALTEK's products are sold by description only, REALTEK reserves the rights to make changes in circuit design and/or specification at any time without notice. Accordingly, the reader is cautioned to make sure the latest version of data sheets are available before placing orders.

REALTEK Semiconductor Corp.

HEAD OFFICE:

1F, NO. 11, INDUSTRY E. RD. IX,
SCIENCE-BASED INDUSTRIAL PARK,
HSINCHU, 300 TAIWAN, R.O.C.
TEL:886-3-5780211
FAX:886-3-5776047

OFFICE:

3F, NO. 56 WU-KUNG 6 RD.,
WU-KU INDUSTRIAL PARK,
TAIPEI HSIEN, TAIWAN, R.O.C.
TEL:886-2-2980098
FAX:886-2-2980097